

UNITED STATES PATENT AND TRADEMARK OFFICE

BEFORE THE PATENT TRIAL AND APPEAL BOARD

ZILLOW GROUP, INC. and ZILLOW, INC.,
Petitioner,

v.

INTERNATIONAL BUSINESS MACHINES CORP.,
Patent Owner.

IPR2020-01658
Patent 7,072,849 B1

Before CHRISTOPHER M. KAISER, KEVIN W. CHERRY, and
ARTHUR M. PESLAK, *Administrative Patent Judges*.

CHERRY, *Administrative Patent Judge*.

DECISION
Denying Institution of *Inter Partes* Review
35 U.S.C. § 314

I. INTRODUCTION

Zillow Group, Inc. and Zillow, Inc. (“Petitioner”) filed a Petition (Paper 3, “Pet.”) requesting institution of *inter partes* review of claims 1–9, 12–22, and 25 of U.S. Patent No. 7,072,849 B1 (Ex. 1101, “the ’849 patent”). International Business Machines Corp. (“Patent Owner”) filed a Preliminary Response. Paper 7 (“Prelim. Resp.”).

Pursuant to 35 U.S.C. § 314(a), an *inter partes* review may be instituted only if “the information presented in the petition . . . and any [preliminary] response . . . shows that there is a reasonable likelihood that the petitioner would prevail with respect to at least 1 of the claims challenged in the petition.” For the reasons given below, upon consideration of the Petition, the Preliminary Response, and the supporting evidence, we determine Petitioner has not established a reasonable likelihood that it would prevail in showing the unpatentability of claims 1–9, 12–22, and 25 of the ’849 patent. Accordingly, we do not institute an *inter partes* review of the ’849 patent.

II. BACKGROUND

A. *Real Parties in Interest*

The Petition identifies Zillow Group, Inc. and Zillow, Inc. as the real parties-in-interest for Petitioner. Pet. 1. Patent Owner identifies International Business Machines Corp. as the real party-in-interest for Patent Owner. Paper 6, 1 (Patent Owner’s Mandatory Notices).

B. *Related Proceedings*

The parties identify *International Business Machines Corp. v. Zillow Group, Inc. et al.*, Case No. 2:20-cv-00851-TSZ (W.D. Wash.) (filed in the Central District of California and transferred to the Western District of

IPR2020-01658
Patent 7,072,849 B1

Washington; served on September 18, 2019) as the related co-pending district court litigation. Pet. 1; Paper 6, 1.

The parties also identify the following related pending petitions for *inter partes* review: IPR2020-01657, Petition for *Inter Partes* Review of the '849 patent, filed on September 18, 2020; IPR2020-01656, Petition for *Inter Partes* Review of U.S. Patent No. 8,315,904 B2, filed on September 18, 2020; and IPR2020-01655, Petition for *Inter Partes* Review of U.S. Patent No. 7,076,443 B1, filed September 18, 2020. Pet. 1; Paper 6, 1.

C. The '849 Patent

The '849 patent is titled “Method for Presenting Advertising in an Interactive Service.” Ex. 1101, [54]. The '849 patent issued from Application Serial No. 08/158,025, filed Nov. 26, 1993 (*id.* at [21], [22]), which is a divisional of Application Serial No. 07/388,156, filed on July 28, 1989, which is a continuation-in-part of Application Serial No. 07/328,790, filed March 23, 1989, which is a continuation-in-part of Application Serial No. 07/219,931, filed July 15, 1988 (*id.* at [60]).

The '849 patent relates to “presenting advertising in an interactive service provided on a computer network, the service featuring applications which include pre-created, interactive text/graphic sessions.” *Id.* at [57]. The Specification explains that, at the time of the invention, interactive computer networks, such as “a time-sharing network in which multiple users, each at a remote terminal, log onto a host that provides data and software resource[s],” were “successful in making the processing power of large computers available to many users.” *Id.* at 1:34–45. In such networks, however, as the number of users increases, bottlenecks at the host give rise to the need for larger and more complex computer facilities to keep response

times low for “transactional services such as home shopping, banking, and investment maintenance, as well as informational services concerning entertainment, business and personal matters.” *Id.* at 1:47–58. In order to address the cost of a service delivery system that maintains low response times, the Specification contemplates advertising income, such as that sought by “other suppliers of mass-media services such as radio, television, newspapers, and magazines . . . to hold access and subscription prices to affordable levels.” *Id.* at 2:3–14. The Specification contends that “in the case of interactive computer services, it has not been apparent how advertising could be introduced without adversely affecting service speed and content quality, which as noted, are considered essential elements for service success.” *Id.* at 2:15–19.

An illustrative embodiment of an interactive computer network for presenting advertising is depicted in Figure 2, reproduced below.

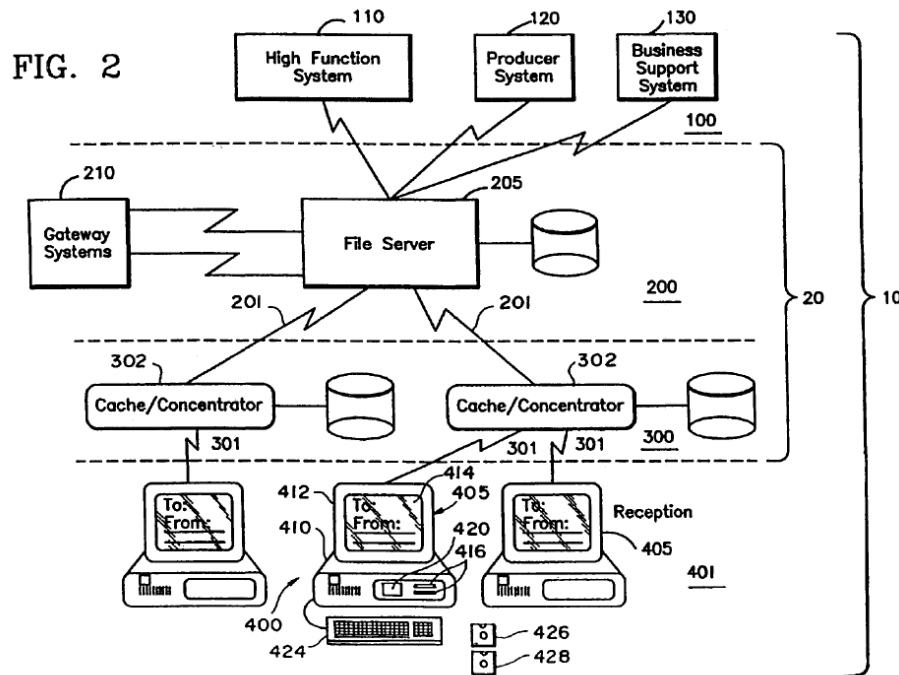

Figure 2 is a schematic view of interactive computer network 10 for presenting advertising. *Id.* at 4:7–11, 4:59–60. Network 10 includes multiple reception systems (RS) 400, each of which may include a conventional personal computer provided with application software. *Id.* at 4:63–67. RS 400 is capable of communication with a host system to receive information containing data in the form of objects (*id.* at 5:51–53), which “carry application program instructions and/or information for display at monitor screen 414 of RS 400” (*id.* at 6:33–34). In particular, “the information used in a RS 400 either resides locally at the RS 400, or is available on demand from the cache/concentrator 300 or the file server 205, via the gateway 210.” *Id.* at 7:60–64. RS 400 selectively stores objects based on predetermined storage criteria so that frequently used objects are stored locally and response time is reduced. *Id.* at 6:57–59.

Figure 3a, reproduced below, depicts a plan view of a display screen of an RS for presenting advertising. *Id.* at 4:12–13.

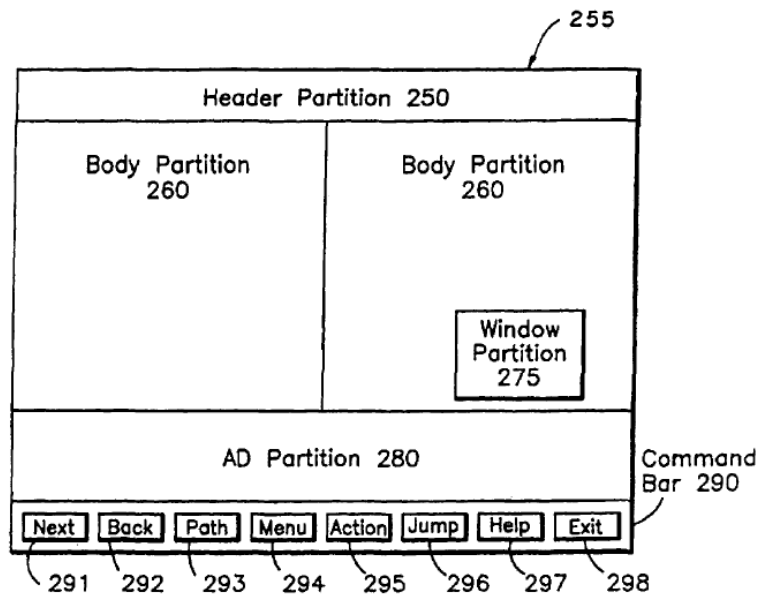

FIG. 3a

Figure 3a shows page 255 of an application that may appear on screen 414 of monitor 412. *Id.* at 9:35–39. Each page may include page partitions, including header page partition 250, body page partitions 260, advertising 280, and command bar 290. *Id.* at 9:39–42, 9:49–52, 9:65–66, 10:34–35. “[T]he display text and graphics necessary to make up the partitions, as well as the program instructions and control data necessary to deliver and sustain the screens and partitions, are formulated from pre-created objects.” *Id.* at 11:11–15. In particular, “advertising objects 510 [not shown in Figure 3a] include the text and graphics that may be presented at ad partition 280.” *Id.* at 12:38–39.

D. Illustrative Claim

Of the challenged claims, claims 1, 8, 13, 14, and 21 are independent. Claims 2–7, 9, 12, 15–20, 22, and 25 depend directly or indirectly from claims 1, 8, 14, or 21. Claim 1, reproduced below is illustrative:

1. A method for presenting advertising obtained from a computer network, the network including a multiplicity of user reception systems at which respective users can request applications, from the network, that include interactive services, the respective reception systems including a monitor at which at least the visual portion of the applications can be presented as one or more screens of display, the method comprising the steps of:
 - a. structuring applications so that they may be presented, through the network, at a first portion of one or more screens of display; and
 - b. structuring advertising in a manner compatible to that of the applications so that it may be presented, through the network, at a second portion of one or more screens of display concurrently with applications, wherein structuring the advertising includes configuring the advertising as objects that include advertising data and;

- c. selectively storing advertising objects at a store established at the reception system.

Ex. 1101, 39:43–61.

E. The Asserted Ground of Unpatentability

Petitioner challenges the patentability of claims 1–9, 12–22, and 25 of the '849 patent on the following ground:

References/Basis	Basis	Claims Challenged
Winter, ¹ Ball ²	§ 103(a) ³	1–9, 12–22, 25

Petitioner supports its Petition with a Declaration by David Eastburn dated September 18, 2020. Ex. 1102.

F. Level of Ordinary Skill

Petitioner proposes that a person of ordinary skill

would have had at least a four-year degree in electrical engineering, computer science, or related field of study, or equivalent experience, and at least two years' experience with content delivery and interface design in interactive computer networks.

Pet. 6 (citing Ex. 1102 ¶¶ 55–56). Patent Owner does not dispute this definition of a person of ordinary skill. *See generally* Prelim. Resp. For purposes of this Decision, we adopt Petitioner's proposed level of ordinary

¹ PETER WINTER, COMMONSENSE VIDEOTEX AND TELETEXT: THE NORTH AMERICAN MARKET (Strauss-Hill Communications, Inc. 1985) (Ex. 1103, "Winter").

² A. J. S. Ball et al., *Videotex Networks*, IEEE Computer, Vol. 13, No. 12, Dec. 1980, at 8–14 (Ex. 1104, "Ball").

³ Because the claims at issue have an effective filing date prior to March 16, 2013, the effective date of the applicable provisions of the Leahy-Smith America Invents Act, Pub. L. No. 112-29, 125 Stat. 284 (2011) ("AIA"), we apply the pre-AIA version of 35 U.S.C. § 103 in this Decision.

skill as it appears to be consistent with the level of skill reflected by the specification and in the asserted prior art references. *See Okajima v. Bourdeau*, 261 F.3d 1350, 1355 (Fed. Cir. 2001) (the prior art itself can reflect the appropriate level of ordinary skill in the art).

G. Claim Construction

We interpret claims in the same manner used in a civil action under 35 U.S.C. § 282(b) “including construing the claim in accordance with the ordinary and customary meaning of such claim as understood by one of ordinary skill in the art and the prosecution history pertaining to the patent.” 37 C.F.R. § 42.100(b) (2019). Only terms that are in controversy need to be construed, and then only to the extent necessary to resolve the controversy. *Nidec Motor Corp. v. Zhongshan Broad Ocean Motor Co.*, 868 F.3d 1013, 1017 (Fed. Cir. 2017).

Petitioner and Patent Owner offer constructions for various limitations. *See* Pet. 7–10; Prelim. Resp. 29–37. For the purposes of this Decision, we determine that the term “advertising objects” requires express construction.

Petitioner only proposes construing the term “objects,” which it contends should be construed as “data structures.” Pet. 7. Patent Owner offers a construction for “advertising objects,” which it contends should be construed as “objects that (1) contain display data to be presented at screen partitions and (2) whose subject matter is selected to concern advertising.” Prelim. Resp. 30. For purposes of this Decision, we do not need to resolve what exactly the correct construction for “objects” is. Instead, we believe it is sufficient to clarify that “advertising objects” are “objects that (1) contain display data to be presented at screen partitions and (2) whose subject matter

is selected to concern advertising.” This is consistent with the language of claims 1 and 14, which state that “advertising objects” are part of the “structuring advertising in a manner compatible to that of the applications so that it may be presented, through the network, at a second portion of one or more screens of display concurrently with applications” and include “advertising data.” *See, e.g.*, Ex. 1101, 39:57–59. This is also consistent with the Specification, which states that “advertising objects are substantially the same as page element objects, with the difference being that, as their name implies, their subject matter is selected to concern advertising.” Ex. 1101, 15:6–12. Page element objects, in turn, are described as follows: “Page element objects . . . contain the display data, i.e., text and graphics, to be presented at screen partitions.” *Id.* at 14:49–51. With that one construction, we determine that no other construction is necessary.

III. DISCUSSION

A. Overview of the Prior Art

1. Overview of Winter

Winter is titled “Commonsense Videotex and Teletext: The North American Market.” Ex. 1103.⁴ Winter is a book that “lay[s] down a blueprint for participation in videotex that reflects significant trends and respects practical issues of cost” and focuses “predominantly on consumer videotex, with due considerations for public access and private systems.” *Id.* at 5.

⁴ Citations to Winter are to the original page numbers of Winter, not the numbers added by Petitioner.

Winter teaches that “[t]he concept of distributing information electronically to consumers using inexpensive terminals hooked to television receivers reached North American shores at about the same time that personal computing began to take hold.” *Id.* at 114. A videotex terminal is “very simple” and functions principally “to receive and transmit data, usually via telephone line connection with a remote computer.” *Id.* But, according to Winter, “microcomputing presages fundamental changes in the entire concept of videotex.” *Id.* at 136. In particular, “data resident on a videotex system can be used to update a customized personal database stored at the user’s end” and “input can be called down, and some sections of the new database can be uploaded for applications requiring major processing that is beyond the capability of the user’s microcomputer.” *Id.* at 137.

Winter states that “there has been a failure to appreciate the true uniqueness of videotex and what that uniqueness portends for advertising.” *Id.* at 307. According to Winter, “videotex graphic capability—even in NAPLPS [a standard for display graphics (*see id.* at 69)] technology—is simply not sufficiently high in resolution to sustain display advertising,” and “renders arcane any attempt to replicate magazine and TV advertising techniques.” *Id.* at 307–308. But, Winter provides that “new approaches are folding advertising more tightly into the content parameters of a particular service and are more closely adhering to the unique attributes of the videotex medium.” *Id.* at 310. In other words, “it is now widely accepted that the very act of becoming a videotex information/service provider represents an entry into the world of advertising.” *Id.* at 312. Winter teaches that one example method of advertising is the “dynamic page merger,” where an “advertising information/service provider can inject a message into a pre-

defined slot, or 'field' of the template.” *Id.* at 313. Winter opines that “[t]he fundamental basis of videotex advertising (marketing) must be interactivity” and “[a]ny form of advertising which stimulates the active participation of the user will achieve greater success than mere image display.” *Id.* at 316.

Winter’s Figure 19, reproduced below, shows a storyboard for defining the visual and functional attributes of a videotex application. *Id.* at 398.

Figure 19: A Sample Storyboard

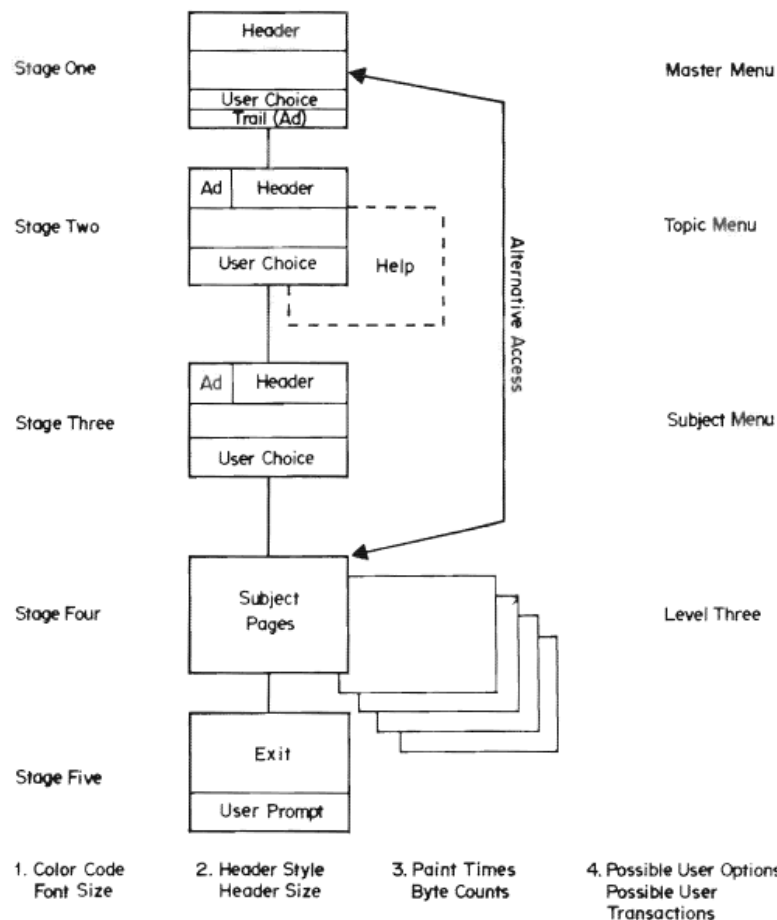

Figure 19 of Winter shows a sample storyboard for a hierarchy of videotex pages from the main menu down to detailed subject pages.

Winter describes a storyboard, such as the one shown in Figure 19, as “a paper plan for the construction of a particular series of visual images” that “specifies the style of pages, their form and their relationship to each other.” *Id.* Put differently, a “storyboard is a prototype in which a user’s progress to, through and out of a videotex package is anticipated.” *Id.* As can be seen in Figure 19, certain pages have a portion labeled “Ad.” Winter further discloses that templates for videotex programming “simplify transaction functioning” and “can also enhance videotex advertising possibilities, by enabling dynamic rotation of ‘strip ads’ or ‘trailers’ to provide maximum exposure by time and placement.” *Id.* at 422.

2. Overview of Ball

Ball is entitled “Videotex Networks.” Ex. 1104, at 8.⁵ Ball is a journal article that relates to “planned and possible videotex network structures,” where “videotex” originally referred to “a low-cost public data or information retrieval service.” *Id.* Ball teaches that second-generation videotex systems “will offer a variety of information services and transactions, such as retrieval from multiple independent data bases, message, electronic mail, conferencing, banking, teleshopping, and interest matching.” *Id.*

Ball describes various components of videotex networks, including the following: user terminals, which use a conventional TV set for display; services, which are “usually implemented on one or several computer systems and/or data bases”; communication media, including “broadcast or cable TV, the telephone system, or integrated service networks based on

⁵ Citations to Ball are to the original page numbers of Ball, not the numbers added by Petitioner.

cables or optical fibers” for connecting to user terminals; information provider terminals, which are “used to prepare and maintain the information available in the videotex network”; and videotex centers, which provide an “effective interface between the network and user terminals.” *Id.* at 9. Ball’s Figure 7, reproduced below, shows one example of a videotex network with a distributed architecture. *Id.* at 14.

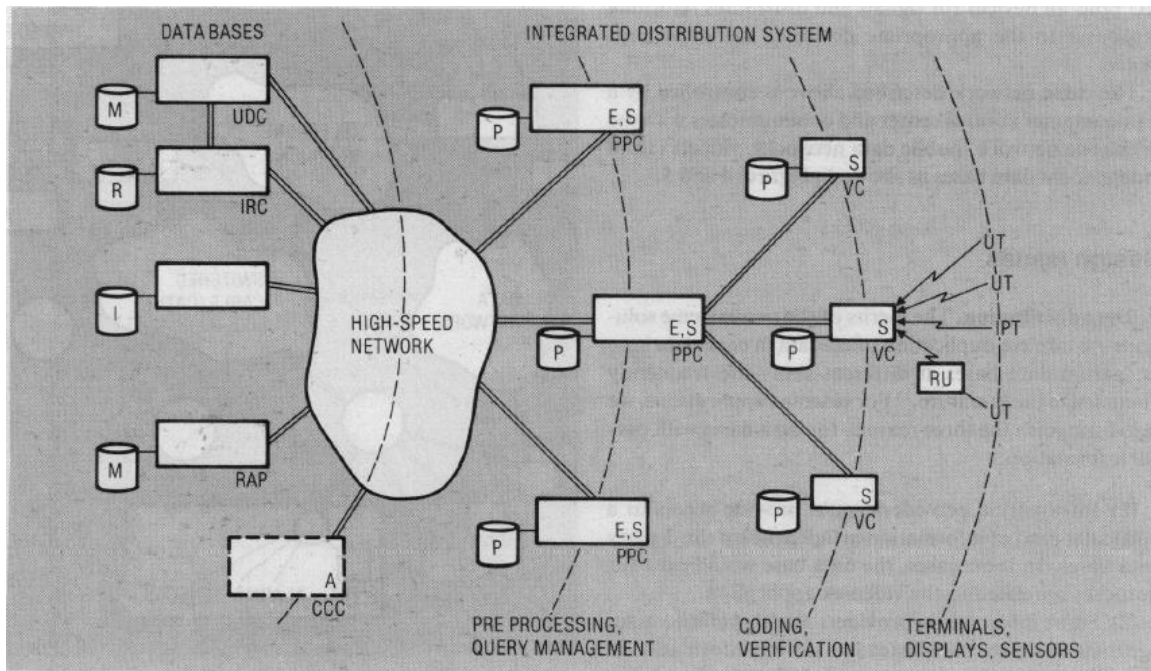

Figure 7 of Ball shows an exemplary videotext network with distributed architecture.

Ball discloses that videotex centers, labeled “VC” in Figure 7, “are gaining importance as sites of local intelligence where network size and complexity require distributed functions.” *Id.* at 9. For example, videotex centers “could provide a directory of available services” and could provide storage management through “[d]own-loading and local mass storage of frequently accessed data from distant data bases.” *Id.* at 13. Ball states that videotex centers could also “alleviate some serious access bottlenecks” by

periodically broadcasting an index of frequently requested content. *Id.*
“User requests for new pages would be examined in the VC and forwarded to the data base for selective retrieval only if the page is not found in the index.” *Id.*

B. Obviousness of Claims 1–9, 12–22, and 25 over Winter and Ball

Petitioner challenges claims 1–9, 12–22, and 25 of the ’849 patent under 35 U.S.C. § 103(a) as unpatentable over Winter and Ball. Pet. 20–54. Patent Owner opposes. Prelim. Resp. 37–59. We have reviewed Petitioner’s and Patent Owner’s assertions, as well as the evidence of record, and, for the reasons discussed below, we conclude that Petitioner has failed to demonstrate a reasonable likelihood of prevailing in showing that claims 1–9, 12–22, and 25 of the ’849 patent would have been obvious over Winter and Ball.

The deficiency is similar for each of the challenged independent claims, and, therefore, each of the challenged dependent claims. For simplicity, we address specifically only the challenge to claim 1 with the understanding that the discussion applies equally to Petitioner’s other challenged claims.

Petitioner contends Winter teaches all the limitations of claim 1, and contends Ball similarly teaches several of the same limitations. *See* Pet. 22–37. In particular, Petitioner contends “Winter discloses selectively storing advertising objects at a store established at the reception system” (*id.* at 34) and “Ball also teaches selectively storing at the reception system” (*id.* at 36).

For an obviousness rationale, Petitioner contends “a POSA would be motivated to implement the combination of Winter and Ball to reduce downloading time, reduce bottlenecking on the system, speed up the

presentation of content, and save money on any connection fees.” *Id.* at 24 (citing Ex. 1102 ¶ 60). Petitioner additionally contends that “combining the teachings of Winter with those of Ball would have yielded predictable results” because

selectively storing advertising objects on a user’s computer (*e.g.*, claim 1), or storing a predetermined amount of advertising data in a store at the user’s computer (*e.g.*, claim 8) . . . and using software running on the user’s computer to select what advertising is presented to users, would have had the predictable result of reducing the back and forth interchange with the central computer system after the initial one, and it would have sped up the responsiveness of the system.

Id. at 22 (citing Ex. 1102 ¶ 61).

Patent Owner contends, among other things, that the combination of Winter and Ball does not teach “selectively storing advertising objects at a store established at the reception system.” Prelim. Resp. 47–53. First, Patent Owner argues Winter only discusses storing generic content locally. *See id.* at 49. Although Petitioner asserts Winter teaches “[t]he advertising information/service provider can inject a message into a pre-defined slot, or “field” of the template,” Patent Owner argues the messages come from a proprietary database, not local storage. *Id.* at 49–50 (quoting Pet. 35–36). Second, Patent Owner argues Ball does not teach storing advertising objects because “Ball does not disclose advertising at all.” *Id.* at 51. Moreover, Patent Owner argues neither Winter nor Ball teaches advertising objects stored “selectively,” under either Patent Owner’s or Petitioner’s proposed construction. *See id.* at 51–53.

We agree with Patent Owner, on this record, that Petitioner has not adequately shown that the combination of Winter and Ball teaches “selectively storing advertising objects at a store established at the reception

system” as claimed. Petitioner points to several portions of Winter that describe storing data at a user’s microcomputer or a local database, but none of these portions specifically relate to storing advertising objects. *See* Pet. 34–36 (citing Ex. 1103, 130, 136–137, 153, 266, 460, 462) (Petitioner cites to pages 46 and 366, but the material relied upon with respect to these cites is actually found on pages 460 and 266, respectively). Nevertheless, Petitioner asserts “[a] POSA would understand that Winter teaches the storage of both applications and advertising objects at the reception system.” *Id.* at 35. In particular, Petitioner identifies Winter’s “dynamic page merger” as a means by which an “advertising information/service provider can inject a message into a pre-defined slot, or ‘field’ of the template, either manually or via a gateway interconnection.” *Id.* (quoting Ex. 1103, 313). Petitioner then asserts “[a] POSA would have understood that in order to perform ‘dynamic page merger’ from locally stored data, both the advertising objects [and] applications would be required to be present on the user’s computer.” *Id.*

Petitioner’s reasoning fails to grapple with Winter’s actual disclosure. Winter describes videotex based on data packages that use “specified input from multi-service providers (including advertisers).” Ex. 1103, 420–421. Such “[m]ulti-source input . . . leads to the formation of a unified data package” that is “facilitated by gateways and a consequent shift in production focus away from the page as a complete entity and into the components of a page.” *Id.* at 421–422. “Such components ‘fit’ into a pre-designed template or ‘mask.’” *Id.* at 422. One template method with “[r]emote inputting via gateway enables a full page of information to flow onto the template interactively during an actual user session.” *Id.* Further,

templates “enhance videotex advertising possibilities, by enabling dynamic rotation of ‘strip ads’ or ‘trailers’ to provide maximum exposure by time and placement.” *Id.* Winter also states that “[t]he advertising information/service provider can inject a message into a predefined slot, or ‘field’ of the template” and use “macros . . . to reduce the amount of data on transmission” and that messages come from a “proprietary database . . . assembled and maintained by the advertiser with assistance from the provider.” Ex. 1103, 62, 338. Based on this disclosure, it is clear that Winter’s dynamic page merger technique relies on gateways, not the local computer, to assemble different inputs, including advertising, into a videotex page.

As noted above, Petitioner’s obviousness rationale asserts that “selectively storing advertising objects on a user’s computer (*e.g.*, claim 1) . . . would have had the predictable result of reducing the back and forth interchange with the central computer system after the initial one, and it would have sped up the responsiveness of the system.” Pet. 22. While it may be true that one of ordinary skill in the art would have been motivated, in the abstract, to reduce data traffic and speed up responsiveness (*see id.*), this reasoning alone does not explain why one of ordinary skill would have stored advertising objects *selectively* at a reception system in the context of Winter’s dynamic page merger technique. Petitioner’s reasoning seems to gloss over the fact that Winter never discloses performing the “dynamic page merger” at the reception system. *See* Pet. 32–36. Petitioner’s reasoning only begs the questions, why would one of ordinary skill in the art have been motivated to modify Winter’s system to perform Winter’s

dynamic page merger at the reception system, and would it really have been predictable at the time of the invention?

Petitioner's problem is that, given Winter's disclosure, it appears that the difference between the prior art and the claimed invention is greater than Petitioner admits. To overcome this gap, Petitioner seems to suggest that using NAPLPS⁶ macros somehow aids in performing dynamic page merger from locally stored advertising because NAPLPS would "reduce the amount of data on transmission." *See* Pet. 35–36. But NAPLPS is just a "color and graphics standard for communicating microcomputers" (Ex. 1103, 45), and it is not clear how simply using a standard already in use in reception systems that do not store advertising objects locally would allow for dynamic page merger to occur locally or how Petitioner or its expert can assert that a person of ordinary skill would have known to use NAPLPS in this manner. As Patent Owner correctly contends, none of the cited discussion of NAPLPS in Winter refers to configuring advertising in videotex pages. Prelim. Resp. 45. In fact, Winter states that "videotex graphic capability — even with NAPLPS technology — is simply not sufficiently high in resolution to sustain display advertising." Ex. 1103, 332–333. Given this discussion, it is difficult, without more explanation and support, to understand how a person of ordinary skill reviewing Winter and Ball would have arrived at the arrangement that Petitioner now suggests.

Indeed, even assuming NAPLPS could be used as Petitioner contends, Petitioner fails to show that Winter teaches that NAPLPS is used in dynamic

⁶ Petitioner describes NAPLPS as "a protocol or standard that defines the format or structure of packets of information (i.e., data) that are sent from the remote computer to the user terminal or computer and in some cases stored locally." Pet. 32 (citing Ex. 1102 ¶ 7).

page merger at all or that Winter even suggests that it could be so used. Instead, Petitioner seems to take various unrelated disclosures of the expansive Winter reference and reconstruct them in ways not contemplated or disclosed in Winter. Petitioner's expert Mr. Eastburn does not aid in providing some rationale or support for Petitioner's contention of storing advertising objects locally in Winter's dynamic page merger technique because the relevant portion of Mr. Eastburn's declaration is merely a reproduction of Petitioner's arguments. *See* Ex. 1102 ¶¶ 79–81. Importantly, when Mr. Eastburn makes significant leaps from the disclosure—such as when he testifies that “a POSA would understand that for advertising pre-fetched with the NAPLPS macro feature, the advertising information/service provider can inject a single character macro name into a pre-defined slot, or ‘field’, thus referring to the advertising object store at the reception system by an object identifier” or that “[a] POSA also would have understood that a pre-determined number of advertising messages, particularly ones customized to a specific user's profile, could be prefetched and stored at the reception system using NAPLPS Macros and incorporated into page displays by simply inserting a single character reference to a macro during the ‘dynamic page merger’ process”—there is no citation or explanation how he makes these leaps. Ex. 1102 ¶¶ 79, 80. In short, Petitioner's obviousness rationale does not support the proposed modification to Winter of “perform[ing] ‘dynamic page merger’ from locally stored data.” Pet. 35.

Petitioner does not show that Ball cures the deficiency of Winter discussed above. Petitioner relies on Ball for the general proposition that there are advantages to local storage of frequently used data. *See* Pet. 36–37

(citing Ex. 1104, 12–13). Petitioner does not explain how Ball provides any reason to modify Winter’s dynamic page merger technique to use locally stored advertising objects. As Patent Owner asserts (Prelim. Resp. 51), Ball does not relate to advertising at all, and so Ball does not add substantively to Winter with respect to the claim 1 limitation of “selectively storing advertising objects at a store established at the reception system.”

“While the Supreme Court made clear that a mechanical application of the teaching-suggestion-motivation test, requiring an explicit teaching in the prior art, is inappropriate, ‘[w]e must still be careful not to allow hindsight reconstruction of references to reach the claimed invention without any explanation as to how or why the references would be combined to produce the claimed invention.’” *Kinetic Concepts, Inc. v. Smith & Nephew, Inc.*, 688 F.3d 1342, 1368 (Fed. Cir. 2012). Here, it was incumbent on Petitioner to provide a complete explanation of why a person of ordinary skill would have been motivated to depart so far from what Winter discloses and why it would have been obvious to piece together and reassemble these various disparate disclosures of Winter in this particular manner to arrive at the claimed invention. To show a reasonable likelihood of succeeding in showing a person of ordinary skill would have used NAPLPS in the “dynamic page merger” process to meet the “selectively storing” limitation—a use seemingly not contemplated by Winter or Ball—requires additional support and explanation beyond conclusory testimony. *See Plantronics v. Aliph, Inc.*, 724 F.3d 1343, 1355 (Fed. Cir. 2013) (“Where, as here, the necessary reasoning is absent, we cannot simply assume that ‘an ordinary artisan would be awakened to modify prior art in such a way as to lead to an obviousness rejection.’ It is in such circumstances, moreover, that

it is especially important to guard against the dangers of hindsight bias.” (citation omitted)). Accordingly, we determine that Petitioner has not adequately “articulated reasoning with some rational underpinning to support the legal conclusion of obviousness.” *KSR Int’l Co. v. Teleflex Inc.*, 550 U.S. 398, 418 (2007) (quoting *In re Kahn*, 441 F.3d 977, 988 (Fed. Cir. 2006)).

IV. CONCLUSION

For the reasons discussed above, we conclude Petitioner has failed to demonstrate a reasonable likelihood of prevailing with respect to at least one of the challenged claims. Accordingly, we do not institute *inter partes* review of the ’849 patent.

V. ORDER

For the reasons given, it is:

ORDERED that *inter partes* review is not instituted for any claim of the ’849 patent.

IPR2020-01658
Patent 7,072,849 B1

PETITIONER:

Shawn Blackburn
SUSMAN GODFREY LLP
sblackburn@susmangodfrey.com

PATENT OWNER:

Yung-Hoon Ha
Theodoros Konstantakopoulos
William Vieth
Alexandra Kochian
DESMARAIS LLP
yha@desmaraisllp.com
tkonstantakopoulos@desmaraisllp.com
wvieth@desmaraisllp.com
akochian@desmaraisllp.com