

UNITED STATES PATENT AND TRADEMARK OFFICE

BEFORE THE PATENT TRIAL AND APPEAL BOARD

FELLOWES, INC.,
Petitioner,

v.

TREEFROG DEVELOPMENTS, INC.,
Patent Owner.

IPR2020-01509
Patent 8,526,180 B2

Before JOSIAH C. COCKS, GRACE KARAFFA OBERMANN, and
KEVIN C. TROCK, *Administrative Patent Judges*.

COCKS, *Administrative Patent Judge*.

DECISION
Denying Institution of *Inter Partes* Review
35 U.S.C. § 325(d); 37 C.F.R. § 42.108

I. INTRODUCTION

A. Background and Summary

Fellowes, Inc. (“Petitioner”) filed a Petition requesting *inter partes* review of claims 1–5, 7, 8, 10–14, 16, 17, 19–24, 26, and 27 (“the challenged claims”) of U.S. Patent No. 8,526,180 B2 (“the ’180 patent,” Ex. 1001). Paper 1 (“Pet.”). Treefrog Developments, Inc. (“Patent Owner”) filed a Preliminary Response to the Petition. Paper 10 (“Prelim. Resp.”).

We have authority under 35 U.S.C. § 314, which provides that an *inter partes* review may not be instituted unless the information presented in the Petition shows that “there is a reasonable likelihood that the petitioner would prevail with respect to at least 1 of the claims challenged in the petition.” 35 U.S.C. § 314(a); *see also* 37 C.F.R. § 42.4(a) (“The Board institutes the trial on behalf of the Director.”).

For the reasons that follow, we exercise our discretion based on the facts of this proceeding and decline to institute an *inter partes* review of the ’180 patent under 35 U.S.C. § 325(d).¹

B. Related Proceedings

The parties identify the following pending litigation as involving the ’180 patent: *Otter Products, LLC v. Fellowes, Inc.*, No. 19-cv-06195 (N.D. Ill. Sept. 2019) (“District Court Action”). Pet. 1; Paper 4 at 2. The parties also identify petitions that challenge claims of other patents asserted in the District Court Action, filed in IPR2020-00852, IPR2020-00869,

¹ We may exercise such discretion when “the same or substantially the same prior art or arguments previously were presented to the Office.” 35 U.S.C. § 325(d).

IPR2020-01435, IPR2020-01543, and IPR2020-01575. Pet. 1–2; Paper 4 at 2.

C. The '180 Patent (Ex. 1001)

The '180 patent is titled “Housing for Encasing an Object Having an Electrical Connection.” Ex. 1001, code (54). The Abstract of the '180 patent is reproduced below:

This disclosure relates generally to an apparatus and/or system for housing a device. The apparatus includes a housing that is configured such that a device may be fitted within the housing and thereby be protected, such as from shocks and/or liquid. The housing may include top and bottom members that may be removably coupled together so as to form the housing. Each top and bottom member optionally includes front and back surfaces surrounded by a perimeter. The perimeter is defined by proximal and distal ends as well as opposing sides. The top and bottom members may include respective clasp mechanisms that extend along the perimeter of the top and bottom members. The clasp mechanisms are configured for coupling the top and bottom members with one another thereby sealing the housing, for instance, in a shockproof and/or water tight seal.

Id. at code (57).

D. Illustrative Claim

Claim 1 is illustrative of the claims at issue and is reproduced below:

1. An apparatus for covering at least part of a mobile computing device having a touch screen display, the mobile computing device further having an electrical connection in a housing that houses the mobile computing device, the apparatus comprising:

an encasement that covers at least part of the mobile computing device that includes the electrical connection, the encasement having a bottom member to cover at least a first portion of the mobile computing device, and a top member to

cover at least a second portion of the mobile computing device, the top member configured to allow touch access to the touch screen display;

a coupling mechanism to couple the top member with the bottom member to cover the first and second portions of the mobile computing device, and to seal the top member with the bottom member;

an aperture in the encasement proximate the electrical connection, the aperture having a gasket seat;

a door for attaching to the encasement proximate the aperture, the door having an open configuration to enable access to the electrical connection of the mobile computing device, and a closed configuration to close the aperture in the encasement; and

a gasket for being seated on the gasket seat to seal the aperture in the encasement when the door is in the closed configuration, the gasket being connected with the encasement by a tether.

Ex. 1001, 80:15–41.

E. Evidence Relied Upon

Petitioner relies on the following references:

Reference²	Publication/Patent Number	Exhibit
Cleereman	US 2007/0158220 A1, published July 12, 2007	1004
Richardson	US 2006/0274493 A1, published Dec. 7, 2006	1005
Kuhn	EP 1 583 251 A1, published May 10, 2005	1007
Noda	US 5,583,742, issued Dec. 10, 1996	1008

² Although Petitioner mostly refers to the references by number, we refer to them by the first named inventor consistent with standard convention.

F. Asserted Grounds of Unpatentability

Petitioner asserts that the challenged claims are unpatentable based on the following grounds:

Claim(s) Challenged	35 U.S.C. §	Reference(s)/Basis
1–5, 7, 8, 10–14, 16, 17, 19–24, 26, 27	102	Cleereman
1–5, 7, 8, 10–14, 16, 17, 19–24, 26, 27	103	Cleereman, Richardson
1–5, 7, 8, 10–14, 16, 17, 19–24, 26, 27	103	Kuhn, Cleereman
1–5, 7, 8, 10–14, 16, 17, 19–24, 26, 27	103	Kuhn, Cleereman, Richardson
1–5, 7, 8, 10–14, 16, 17, 19–24, 26, 27	103	Kuhn, Noda
1–5, 7, 8, 10–14, 16, 17, 19–24, 26, 27	103	Kuhn, Noda, Richardson

Pet. 14. The Petition is supported by the Declaration of Dr. Charles Garris. Ex. 1009. The Preliminary Response is supported by the Declaration of Dr. T. Kim Parnell. Ex. 2002.

II. ANALYSIS

A. 35 U.S.C. § 325(d)

We have discretion to deny review when “the same or substantially the same prior art or arguments previously were presented to the Office.” 35 U.S.C. § 325(d). In that respect, § 325(d) provides that the Director may elect not to institute a proceeding if the challenge to the patent is based on matters previously presented to the Office. *Advanced Bionics, LLC v. Med-El Elektromedizinische Geräte GmbH*, IPR2019-01469, Paper 6 at 7 (PTAB

Feb. 13, 2020) (precedential) (“*Advanced Bionics*”). Both Petitioner and Patent Owner have offered arguments pertaining to discretionary denial of *inter partes* review. Pet. 9–12; Prelim Resp. 23–29. For the reasons that follow, we determine, in this case, that exercise of our discretion to deny institution pursuant to § 325(d) is warranted.

In evaluating matters under § 325(d), the Board uses the following two-part framework: (1) determining whether the same or substantially the same art previously was presented to the Office or whether the same or substantially the same arguments previously were presented to the Office; and (2) if either condition of the first part of the framework is satisfied, determining whether the petitioner has demonstrated that the Office erred in a manner material to the patentability of challenged claims. *Advanced Bionics*, Paper 6 at 8. The Board institutes trial on behalf of the Director. 37 C.F.R. § 42.4(a); *Advanced Bionics*, Paper 6 at 7 n.7.

In applying the two-part framework, we consider several non-exclusive factors, including:

- (a) the similarities and material differences between the asserted art and the prior art involved during examination;
- (b) the cumulative nature of the asserted art and the prior art evaluated during examination;
- (c) the extent to which the asserted art was evaluated during examination, including whether the prior art was the basis for rejection;
- (d) the extent of the overlap between the arguments made during examination and the manner in which Petitioner relies on the prior art or Patent Owner distinguishes the prior art;
- (e) whether Petitioner has pointed out sufficiently how the Examiner erred in its evaluation of the asserted prior art; and
- (f) the extent to which additional evidence and facts presented in the Petition warrant reconsideration of the prior art or arguments.

Becton, Dickinson & Co. v. B. Braun Melsungen AG, IPR2017-01586, Paper 8 at 17–18 (PTAB Dec. 15, 2017) (precedential as to Section III.C.5, first paragraph) (“*Becton, Dickinson*”). If, after review of factors (a), (b), and (d), we determine that the same or substantially the same art or arguments previously were presented to the Office, then factors (c), (e), and (f) relate to whether the petitioner demonstrates that the Office erred in a manner material to the patentability of the challenged claims. *Advanced Bionics*, Paper 6 at 10.

1. The Same or Substantially the Same Art Presented to the Office

Here, Patent Owner contends that, of the four prior art references that are applied by Petitioner in the proposed grounds of unpatentability, three of them (Cleereman, Richardson, Noda) were before the Examiner in charge of Application 13/689,663 (“the ’663 application”) that became the ’180 patent. Prelim. Resp. 25–26. We agree with Patent Owner’s representation that each of those references appears on an Information Disclosure Statement in which the Examiner expressed that “All references considered except where lined through.” *Id.*³ None of the above-noted references were lined through. *See* Ex. 1002 at 148–150. We also note that each of Cleereman, Richardson (as the ’512 patent), and Noda appears on the face of the ’180 patent as “References Cited.” *See* Ex. 1001, code (56). Petitioner does not dispute, and indeed acknowledges, that those references were of record during

³ Patent Owner cites to pages 148–151 of Exhibit 1002. Prelim. Resp. 25–26. We concur with Patent Owner’s assessment (*id.* at 25) that Richardson (US Patent Publication 2007/0158220) matured into US Patent No. 7,609,512 (“the ’512 patent”), and constitutes the equivalent disclosure of that patent.

prosecution of the '663 application. *See* Pet. 9. Although it is apparent that a sizeable number of references were presented to the Examiner during prosecution of the '663 application, we do not discern adequate reason on the present record to discount the Examiner's representation that the disclosures of each of Cleereman, Richardson, and Noda were "considered."

It does not appear that Kuhn was before the Examiner during prosecution of the '663 application. There is, however, a credible basis on the record at hand to conclude that Kuhn's disclosure is cumulative to prior art that was before the Examiner. In that respect, the Examiner initially rejected many of the claims of the '663 application as anticipated by U.S. Patent No. 7,495,895 to Carnevali (Ex. 1006, "Carnevali"). *See* Ex. 1002, 521–523 (rejecting claims 1–9, 11–19, and 21–30). The Examiner, however, indicated that dependent claim 10 "would be allowable if rewritten . . . to include all of the limitations of the base claim and any intervening claim." *Id.* at 522. Claim 10 initially depended from claim 1 of the '663 application and added the requirement of "wherein the gasket is connected with the encasement by a tether." Ex. 1002, 710. The record reflects that the noted requirement of claim 10 was added to claim 1 of the '663 application, which ultimately issued as claim 1 of the '180 patent. *Compare* Ex. 1002, 164 *with* Ex. 1001, 80:15–41.

In the Petition, Petitioner applies Kuhn as disclosing all the features of claim 1 of the '180 patent "except for the gasket/door/cover being connected to the encasement with a tether." Pet. 45. Thus, Petitioner applies Kuhn as constituting equivalent disclosure to that which the Examiner viewed as present in Carnevali. Such a circumstance presents a reasonable and

adequate foundation to view Kuhn's disclosure as cumulative to prior art, *i.e.*, at least Carnevali, that was evaluated during examination.

Accordingly, we conclude that the Petition relies on prior art that was the same or substantially the same prior art that previously was presented to the Office, which is one of the conditions of the first part of the *Advanced Bionics* framework. *See Advanced Bionics*, Paper 6 at 8. Because that condition is satisfied, we turn to the second part of the framework. *See id.* at 10.

2. *Whether the Office erred in a Manner Material to Patentability*

The second part of the *Advanced Bionics* framework focuses on identification of material error by the Examiner. We generally take into account *Becton, Dickinson* Factors (c), (e), and (f) as a part of this analysis. *Advanced Bionics*, Paper 6 at 8. Here, Petitioner proposes that such error should be inferred due to the number of prior art references that were before the Examiner during examination of the '663 application. In particular, according to Petitioner, the Examiner was "inundated . . . with nearly 300 prior art references" and "may have overlooked any such relevant references." Pet. 11. The basis for that contention is that, in its view, Petitioner provides a "strong" case of unpatentability in connection with each of the proposed anticipation grounds and obviousness grounds, and that the "strength of the prior art's teachings against the claims, weigh in favor of institution under the *Becton* factors." Pet. 11 (citing *Becton*, Paper 8 at 17–18). In effect, Petitioner argues that all of its proposed grounds are of such notable strength that error on the part of the Examiner must be the reason why the claims of the '180 patent were allowed. It is, therefore, manifest that assessment of the "strength" of the proposed grounds is in order.

a) The Grounds Based on Cleereman

Petitioner proposes that claims 1–5, 7, 8, 10–14, 16, 17, 19–24, 26, and 27 of the '180 patent are anticipated by Cleereman. Petitioner also proposes that those claims are unpatentable over Cleereman taken with Richardson.

Cleereman is titled “Impact-Resistant Case with Sealable Opening.” Ex. 1004, code (54). Figure 3 of Cleereman is reproduced below:

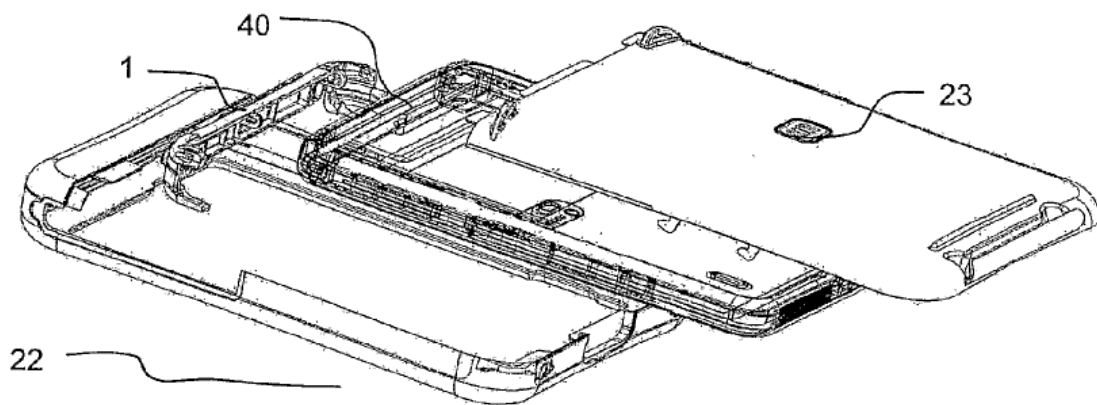

FIG. 3

Figure 3 shows “an exploded perspective view of a web table with its protective case.” *Id.* at ¶ 19. Protective case 30 (not numbered in Figure 3) includes top portion 22 and bottom portion 23. *Id.* at ¶ 21.

Claim 1 requires an encasement with a top and bottom member and a “coupling mechanism to couple the top member with the bottom member.” Ex. 1001, 80:20–28. Petitioner contends that the “coupling mechanism” requirement generally is met because of disclosure in Cleereman that its top member 22 and bottom member 23 are “mated.” Pet. 28–29 (citing Ex. 1004 ¶ 36). We agree with Patent Owner, however, that Petitioner does not point to any particular structure as constituting the “coupling mechanism” in

Cleereman that facilitates the mating of the top and bottom members. *See* Prelim. Resp. 31–32. According to Petitioner, “[t]he fact that those members 22, 23 are mated, and [the] resulting case is impact and water resistant, confirms they are coupled, and thus have a coupling mechanism that provides sealing.” Pet. 29. In effect, Petitioner advances the position that a coupling mechanism is inherent to the mating of members 22 and 23, but does not provide adequate evidence or reasoning for that position. To be sure, as a mated pair, members 22 and 23 are understood reasonably as being coupled, but that circumstance does not, itself, necessarily give rise to an inference that there must be specific, dedicated structure that is the “mechanism” that is accomplishing the coupling. Petitioner does not articulate why mating of the members cannot be accomplished in a manner that omits a separate structure recognizable as a “coupling mechanism.” We discern that, although Petitioner’s expert, Dr. Garris, also takes the position that a “coupling mechanism” is necessarily present (*see* Ex. 1009 ¶ 44), he does not point to adequate supporting evidence for that view. We further note that Patent Owner’s expert, Dr. Parnell, disagrees with Petitioner’s position. *See* Ex. 2002 ¶¶ 65–66. We conclude that the record is wanting of adequate supporting evidence or explanation for Petitioner’s position contention on how Cleereman discloses the claimed “coupling mechanism.”

Further still, claim 1 also requires that the “coupling mechanism” perform a separate function, which is “to seal the top member with the bottom member.” Ex. 1001 80:29–30. Here too, Petitioner and Dr. Garris are of the view that such function arises inherently or intrinsically from the mating of Cleereman’s top member 22 with bottom member 23. *See* Pet. 29; Ex. 1009 ¶ 44. Patent Owner and Dr. Parnell disagree, arguing that

Petitioner has not established adequately that it is a specific coupling mechanism structure that operates to seal the top and bottom members. *See* Prelim. Resp. 31–32; Ex. 2002 ¶¶ 65–66. We share Patent Owner’s skepticism based on the record at hand.

In its proposed obviousness ground based on Cleereman and Richardson, Petitioner applies Richardson as an alternate approach to account for the “touch screen display” appearing in the preamble of independent claims 1, 10, and 20. *See, e.g.*, Pet. 42–44. Petitioner also generally points to Richardson as disclosing a “coupling mechanism.” *See id.* at 44–45.

With respect to Petitioner’s reliance on Richardson pertaining to a “coupling mechanism,” Petitioner points to Richardson’s disclosure of latches and an o-ring seal. Pet. 44. Petitioner likens those components as together forming a coupling mechanism and argues that coupling mechanisms in general are “extremely well known.” *Id.* Petitioner also urges that “a [person of ordinary skill in the art] would consider combining [Cleereman] and [Richardson], as they each have device encasements with similar features that address access to electrical connections, and confirm they can be used on various encasement designs.” *Id.* at 45. Patent Owner challenges Petitioner as offering “no explanation of how the structure of Cleereman could be modified by the teachings of Richardson[] to teach the limitations of Claims 1, 10, 10, and 20, either directly or through citation to *ipse dixit* of in the declaration of Dr. Garris.” Prelim. Resp. 43–44. Patent Owner also contends that Petitioner’s proposed combination is based on “hindsight” (*id.* at 42) and characterizes the proposal as “conclusory.” *Id.* at 44.

In reviewing the Petition and its proposed combination of Cleereman and Richardson, we discern that it provides little explanation as to how any of Richardson's disclosed latches or o-ring seal would be applied to, or implemented on, Cleereman's case. In that respect, it is not readily apparent on this record how the separate latches and o-ring seal would be configured so as to constitute the "coupling mechanism" that, itself, serves "to seal the top member with the bottom member" as required by claim 1. Furthermore, although Petitioner states that it would have been obvious to form a case for a device as to render a contained device "securely contained and protected from water and other liquids," that reasoning is presented only generally and, in our view, is less than robust as to why a skilled artisan would have combined the teachings of Cleereman and Richardson to achieve an apparatus having a coupling mechanism that meets claim 1. *See* Pet. 44.

For the foregoing reasons, we conclude that, as a part of its proposed anticipation ground based on Cleereman, the failure of Petitioner to account for the distinct element of a coupling mechanism to couple top and bottom members and to serve an additional function of sealing the members presents a notable weakness in the merits of Petitioner's proposed ground. We also are not satisfied on this record that Petitioner provides a sufficiently concrete basis or robust reasoning for combining the teachings of Cleereman and Richardson. As a result, we conclude that those weaknesses do not favor Petitioner's view that the Examiner committed error in a manner material to patentability in permitting the issuance of the '180 patent over the prior art that was of record, in particular, Cleereman and Richardson.

b) The Grounds Based on Kuhn

Petitioner also proposes four separate grounds of obviousness applied to claims 1–5, 7, 8, 10–14, 16, 17, 19–24, 26, and 27 based primarily on Kuhn taken with one or more of Cleereman, Richardson, and Noda. As discussed above, Kuhn provides cumulative disclosure to prior art that was considered by the Examiner during examination. Petitioner contends that Kuhn discloses all the features of the above-noted claims including a “plug” that, in Petitioner’s view, accounts for several features of independent claims 1, 10, and 20. *See* Pet. 48. For instance, in Petitioner’s view, Kuhn’s “plug” disclosure accounts for an “‘aperture’ through the encasement wall proximate an electrical connection” and “the plug is inserted for watertight sealing for the same purposes as ‘door’/’cover’/’gasket’ in claims 1, 10 and 20.” Pet. 48 (citing Ex. 1007 ¶ 47). We observe that Kuhn’s description of a “plug” is limited to a single paragraph of its disclosure which simply states the following:

Alternatively, a cable connection between the headset and mobile phone would also be conceivable. In this case, watertight bushings would have to be designed on the housing for the cable or rather a plug. For operation without cable, these bushings would have to be watertight closed with suitable plugs.

Ex. 1007 ¶ 47.

Yet, from that brief and limited disclosure of a “plug,” Petitioner attempts to meet multiple features of the claims, including, for instance, the following features of claim 1:

an aperture in the encasement proximate the electrical connection, the aperture having a gasket seat;
a door for attaching to the encasement proximate the aperture, the door having an open configuration to enable access to the electrical connection of the mobile computing device, and

a closed configuration to close the aperture in the encasement;
and

a gasket for being seated on the gasket seat to seal the aperture in the encasement when the door is in the closed configuration.

Ex. 1001, 80:32–40.

Petitioner does not explain adequately why Kuhn’s “plug” disclosure is so expansive as to account for the above-noted features of claim 1, including, for example, the separate and distinct elements in claim 1 that are the “door” and the “gasket.” Moreover, in connection with Kuhn’s disclosure, and as noted by Patent Owner (*see, e.g.*, Prelim. Resp. 49–50), the Petition makes no actual reference to a “gasket seat” or what structure in Kuhn constitutes the claimed “gasket seat.”

Furthermore, Petitioner contends that Kuhn discloses all the features of the challenged claims except that “[w]hat Kuhn does not teach is what exactly its plug looks like, or that its plug is connected by a tether[.]” *See, e.g.*, Pet. 48, 52. Notably, it is the “tether” aspects of the claims that the Examiner determined was a feature that moved the claims beyond the teachings of Carnevali, a disclosure to which Kuhn is cumulative. Petitioner points to each of Cleereman and Noda as allegedly disclosing the required tether features of the claims and reasons that one of ordinary skill in the art would have relied on “commonsense to avoid the plug being lost” as the reason to have combined the teachings of the prior art to arrive at the claimed invention, including the noted tether feature. *See* Pet. 49, 55. Dr. Garris also so testifies. *See* Ex. 1009 ¶¶ 94, 106. We discern, however, neither Petitioner nor Dr. Garris cites to record evidence to support their arguments and views as to why a skilled artisan would have combined the

teachings of the prior art in the manner proposed. In these circumstances, we detect a classic example of impermissible hindsight bias. *See, e.g., Metalcraft of Mayville, Inc. v. The Toro Co.*, 848 F.3d 1358, 1367 (Fed. Cir. 2017) (“Without any explanation as to how or why the references would be combined to arrive at the claimed invention, we are left with only hindsight bias[.]”)

Additionally, the grounds based on Kuhn are composed in whole or in part in combination with either Cleereman or Noda. Although Petitioner contends that Kuhn discloses all the features of the claims, Petitioner also postulates that Cleereman generally “teaches all the claim limitations relating to the ‘aperture,’ ‘door’/‘cover’/ and ‘tether,’ including the independent claims elements 1[f]-[i], 10[c]-10[f], 20[c]-20[f], and dependent claims 2-5, 7-8, 9-14, 16-17, 19, 21-24, and 26-27.” Pet. 48–49.⁴ Similarly, Petitioner contends that Noda also “meets claim elements 1[f]-[i], 10[c]-10[f], 20[c]-20[f], as well as dependent claims 2-5, 7-8, 9-14, 16-17, 19, 21-24, and 26-27. Pet. 52. Petitioner, however, does not tether these blanket statements to any actual teachings in Cleereman or Noda, or offer any justification or reasoning as to why or how it would have been obvious to one of ordinary skill in the art to combine those alleged teachings with Kuhn.

The above-discussed flaws in the proposed grounds based on Kuhn cast doubt on their propriety, and are far from persuasive in suggesting that the Examiner erred in permitting the ’180 patent to issue.

⁴ Designations such as “1[f]”, “10[c]”, and “20[c]” are shorthand reference identifiers for certain claim features used by Petitioner in its Petition. *See* Pet. 26–36.

3. *Conclusion*—35 U.S.C. § 325(d)

For the foregoing reasons, we conclude that Petitioner relies on the same or substantially the same prior art that was previously presented to the office. Furthermore, Petitioner premises its assertion of Examiner error on the theory of the asserted strength of all its proposed grounds, yet as discussed above, we determine that there are significant weaknesses, in many, if not all, of the proposed grounds. We conclude that the two-part framework of *Advanced Bionics* is satisfied, and that exercise of our discretion to deny institution under 35 U.S.C. § 325(d) is warranted. According, we do so.

B. Other Considerations

Because we exercise our discretion under 35 U.S.C. § 325(d) to deny institution, we determine that it is unnecessary to reach other matters pertaining to the question of whether institution is warranted. These include matters of claim preclusion (*res judicata*) and issue preclusion, for which both parties have taken a position in this proceeding. *See, e.g.*, Pet. 59–64; Prelim. Resp. 14–23. We further observe that there is no requirement that we institute an *inter partes* review, as the decision on whether to institute is discretionary. *See* 35 U.S.C. § 314(a); *see also* *Adaptics Ltd. v. Perfect Co.*, IPR2018-01596, Paper 20 at 17 (PTAB Mar. 6. 2019) (informative).⁵

⁵ As articulated by the panel in *Adaptics*:

Even when a petitioner demonstrates a reasonable likelihood as to at least one claim, however, institution of an IPR remains discretionary. *SAS [Institute Inc. v. Iancu*, 138 S. Ct. 1348,] 1355 [(2018)] (“§ 314(a) invests the Director with discretion on the question whether to institute review”); *Harmonic [Inc. v.*

Institution in this case would require us to overlook significant weaknesses in the asserted grounds of unpatentability stated in the Petition. Stated somewhat differently, we reject Petitioner’s unsubstantiated argument that the asserted grounds are so overwhelmingly strong as to demonstrate error by the Examiner. Accordingly, we determine that exercise of our discretion to deny the Petition is appropriate.

III. CONCLUSION

For the foregoing reasons, we exercise our discretion to deny institution of *inter partes* review under 35 U.S.C. § 325(d).

IV. ORDER

It is

ORDERED that the Petition is *denied* as to all challenged claims, and no trial is instituted.

Avid Tech., Inc., 815 F.3d [1356,] 1367 [(Fed. Cir. 2016)] (“First of all, the PTO is permitted, but never compelled, to institute an IPR proceeding.” (citing 35 U.S.C. § 314(a))). As explained in our Trial Practice Guide Update, “[t]he Director’s discretion is informed by 35 U.S.C. §§ 316(b) and 326(b), which require the Director to ‘consider the effect of any such regulation [under this section] on the economy, the integrity of the patent system, the efficient administration of the Office, and the ability of the Office to timely complete proceedings instituted under this chapter.’” Trial Practice Guide Update, 10 at 9; *see also* Office Patent Trial Practice Guide, August 2018 Update, 83 Fed. Reg. 39,989 (Aug. 13, 2018) (discussing and providing link to Trial Practice Guide Update).

IPR2020-01509
Patent 8,526,180 B2

For PETITIONER:

Bryan Collins
Patrick Doody
William Atkins
Henry Fildes
PILLSBURY WINTHROP SHAW PITTMAN LLP
Bryan.collins@pillsburylaw.com
Patrick.doody@pillsburylaw.com
William.atkins@pillsburylaw.com
Henry.fildes@pillsburylaw.com

For PATENT OWNER:

Andrew Lagatta
MERCHANT & GOULD P.C.
alagatta@merchantgould.com